

AH1012T Series Air Cooler

Symbol

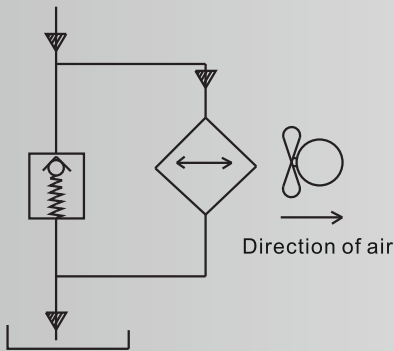

Performance curve

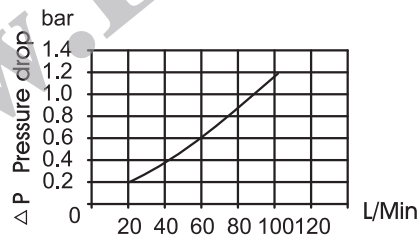
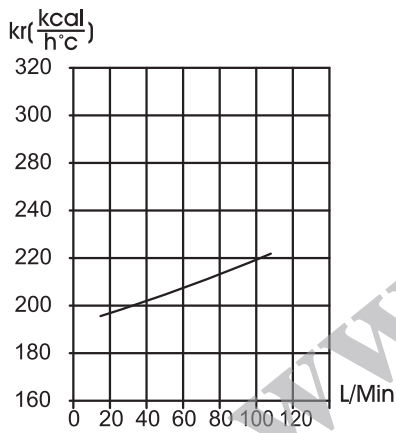

Technical data

Model	Voltage	Max. flow rate (l/min)	Max. working pressure (bar)	Consumed power (W)	Speed (rpm)	Noise (db)	Weight (kg)
AH1012T	DC12V	100	35	100	2890	60	10.5
	DC24V				2700		
	AC220V (50Hz/60Hz)			80	2650		
	AC380V (50Hz/60Hz)						

AH1012T series air cooler dimensions

Unit: mm

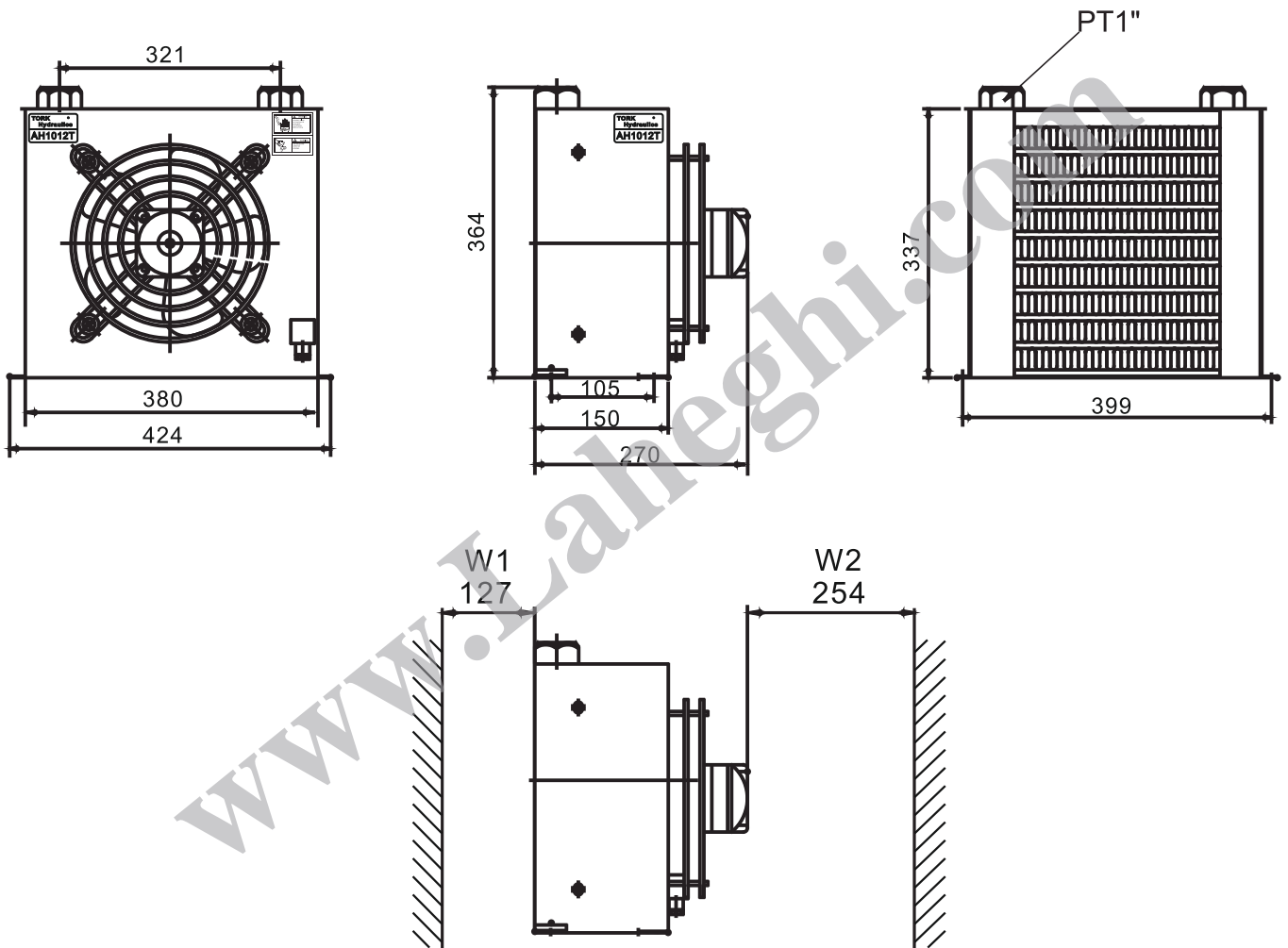

W1 is the min. distance between air inlet and obstacle

W2 is the min. distance between air outlet and obstacle